



Budenberg

Made in Britain

4, Gilchrist Road, Northbank Industrial Park, Irlam, Manchester, UK. M44 5AY.

Tel : +44 (0)161 777 7300

Fax : +44 (0)161 777 7399

Email : sales@budenberg.co.uk

Web : www.budenberg.co.uk

Model: WH

The WH is a high integrity Diaphragm Seal Gauge designed for applications where cleanliness is paramount, ie Brewing, Pharmaceutical, Food and Beverage industries. These units are designed to withstand steam cleaning at elevated temperatures and pressures.

WH-1 ISS /IDF connection including Nut
WH-T Triclamp/Triclover connection
WH-D DIN 11851 connection with Nut

Available in a wide range of options including a choice of dial sizes, connections, materials, filling fluids and options to permit operation at temperatures in excess of 440 Degrees Celsius.

Applications

Designed for continuous operation on gases or liquids where the product to be measured is of a hygienic and or foodstuff nature. Versions are available to withstand pressure pulsations, vibrations and operation at very high temperatures.

Dial Sizes

63mm, 100mm & 150mm are standard.

Pressure Gauges

See separate Pressure Gauge Datasheets for suitable gauges for use on diaphragm seals.

Accuracy Class

1.0% as EN837

Pressure Range

The welded seal units are available in a range of configurations dependant upon the required Dial Size and Operating pressure ranges as follows:
Ranges 0 to 1 Bar up to 0 to 40 Bar
Other pressure units are available on request.

Over range protection

All units will withstand 130% overload as standard up to 40 Bar. Optionally the diaphragm can be set to 'lock off' allowing the unit to withstand an overload up to the maximum pressure rating of the seal unit. This unique feature can be used to avoid the use and cost of additional overload protection valves.

Materials of Construction

Due to the welded construction, all materials including the diaphragm and connection have to be of the same material. Standard - 316L Stainless Steel
Other materials available upon request

DIAPHRAGM SEAL WELDED HYGIENIC CONNECTION



Process connections

1" ISS / IDF including nut

1 1/2" ISS / IDF including nut

2" ISS / IDF including nut

3" ISS / IDF including nut

1 1/2" Triclamp / Triclover in Hastelloy C276

2" Triclamp / Triclover

3" Triclamp / Triclover

1" DIN 11851

2" RJT

Others are available on request.

Filling Fluids

A wide range of filling fluids are available to suit most applications including high temperature and pharmaceutical applications. Standard Options are Mineral Oil, Silicon HT Oil, Medicinal Paraffin, Glycerine, Syltherm XLT & 400.

FDA approved fluids for food and pharmaceutical applications.

Temperature

Normal process operating temperature range: -20 to +100 °C
Elevated temperature operation up to 400 °C can be achieved by the selection of an extended neck option and an associated high temperature filling fluid. See relevant datasheet.
Serial Number printed on the dial.

Pulsation Damper

The welded design allows us to offer a snubber internally to dampen pulsations and beneficially protect the Pressure Gauge.

Certification

A Certificate of conformity traceable to National Standards is supplied free of charge.

Safety

All units are manufactured to comply with EN 837-1 and other regulatory standards including P.E.D.

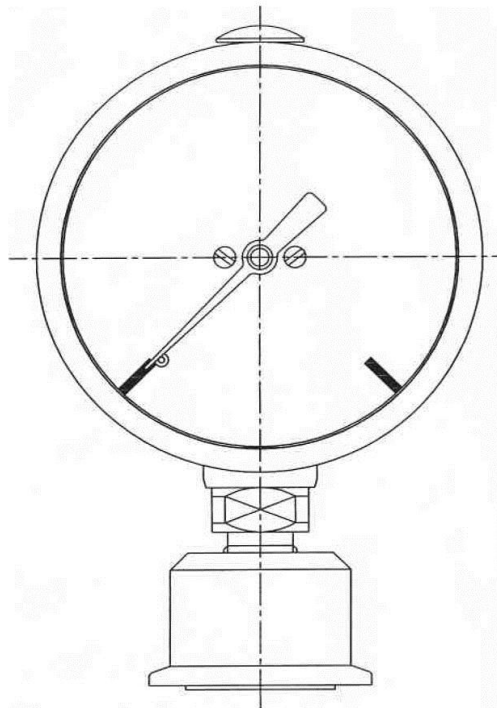

TRI-CLOVER with 100mm Gauge

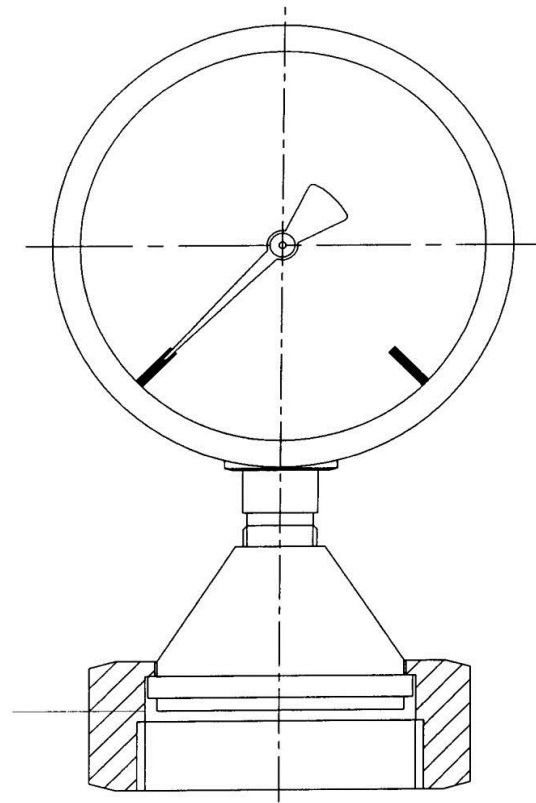

IDF with 100mm Gauge

Options

- WH-1 ISS /IDF connection including Nut
- WH-T Triclamp/Triclover connection
- WH-D DIN 11851 connection with Nut

Extended Neck

For use in elevated temperatures up to 300 °C we can dissipate the effect of heat from the Pressure Gauge by inserting an extended neck between the WF and the pressure gauge.

Remote Mounting

St/steel capillary can be fitted between gauge and seal to protect instrument from heat or vibration

Fitting Transmitters

We have a range of standard and 'Smart' Transmitters that can be used in combination with the WH or we can fit customers own free issue transmitters to most diaphragm seal units

Accessories

Valves and Adaptors

A full range of Needle and Ball Valves to fit the WH - See separate Datasheets.