



Budenberg

Made in Britain

4, Gilchrist Road, Northbank Industrial Park, Irlam, Manchester, UK. M44 5AY.

Tel : +44 (0)161 777 7300

Email : sales@budenberg.co.uk

Fax : +44 (0)161 777 7399

Web : www.budenberg.co.uk

Model: 966MGP

BOURDON TUBE PRESSURE GAUGE SUPASAFE FULL SAFETY PATTERN

An impressive technical specification and wide range of standard features make the SUPASAFE the obvious choice for a wide range of process and engineering applications.

Primarily designed for the harshest of offshore Oil & Gas environments. SUPASAFE provides a very cost effective solution to the process industry and therefore is the ideal 'standard' choice for companies looking to benefit from a stock and range rationalisation.

Meeting all the current National and International specifications and regulatory standards including EN 837, PED etc. SUPASAFE with its inherently safety pattern construction incorporates many features as standard that are designed to provide full protection to the instrument and the operator.



Size

100 mm (4") & 150mm (6")

Mounting

Direct, Surface and Flush

Case & Bezel

Rugged one-piece full Safety Pattern case to S3 standard with a solid baffle partition wall and full blow out back manufactured in 1.6mm thick, 316L stainless steel.

Scale Ranges

0 to 600 mbar to 0 to 1400 bar Pressure
Equivalent units of pressure / vacuum available
Single and dual scales are available

Pressure Element

≤80 Bar – Monel Bourdon Tube
≥81 Bar - Monel Coil

Overload

Units withstands overload pressure up to 130% of FSD
Overload & vacuum stops are fitted on the movement

Option: Mechanical overload clamps fitted internally to enable units to withstand up to 3x the max scale reading

Pressure Connection

3/8", 1/2" BSP
1/2" NPT
Other connections available, contact our Sales Dept for details

Accuracy Class

CL:1 1.0% of FSD as defined in EN837-1
Option: 0.5% of FSD as defined in EN837-1

Temperature

Operating: -20 to +90 °C
Storage: -40 up to +100 °C
Options: for lower or higher operating temperatures, please contact our Sales Office

Dial

White Anodised Aluminium marked in black finish
Single or dual scale

Pointer

Stainless steel coloured black
Options: Micrometer Adjustable

Movement

316L Stainless Steel Construction
Option : Viscous Damped movement to overcome the effects of minor pressure pulsations

Window

3mm Laminated Safety Glass (Standard)
Option: Acrylic Plastic Window

Environmental Rating

IP67 as defined in EN 60 529

Traceability

All instruments are individually calibrated and have an unique Serial Number printed on the dial. A Certificate of Conformity Traceable to National Standards is Supplied Free of Charge

Certification available

BS EN 10204 3.1B Material Certification
Point by Point Test Certificate

Safety

All units are manufactured to comply with EN 837-1, S3 specification and other regulatory standards including PED.

Installation Instructions

Refer to EN 837-2

Temperature Effect

Variation in indication caused by temperature shall not exceed $\pm 0.04 \times (t_2 - t_1)\%$ of the span where:
t1 is the reference ambient temperature in degrees Celsius
t2 is the ambient temperature in degrees Celsius

Dimensions

Model : 966MGP

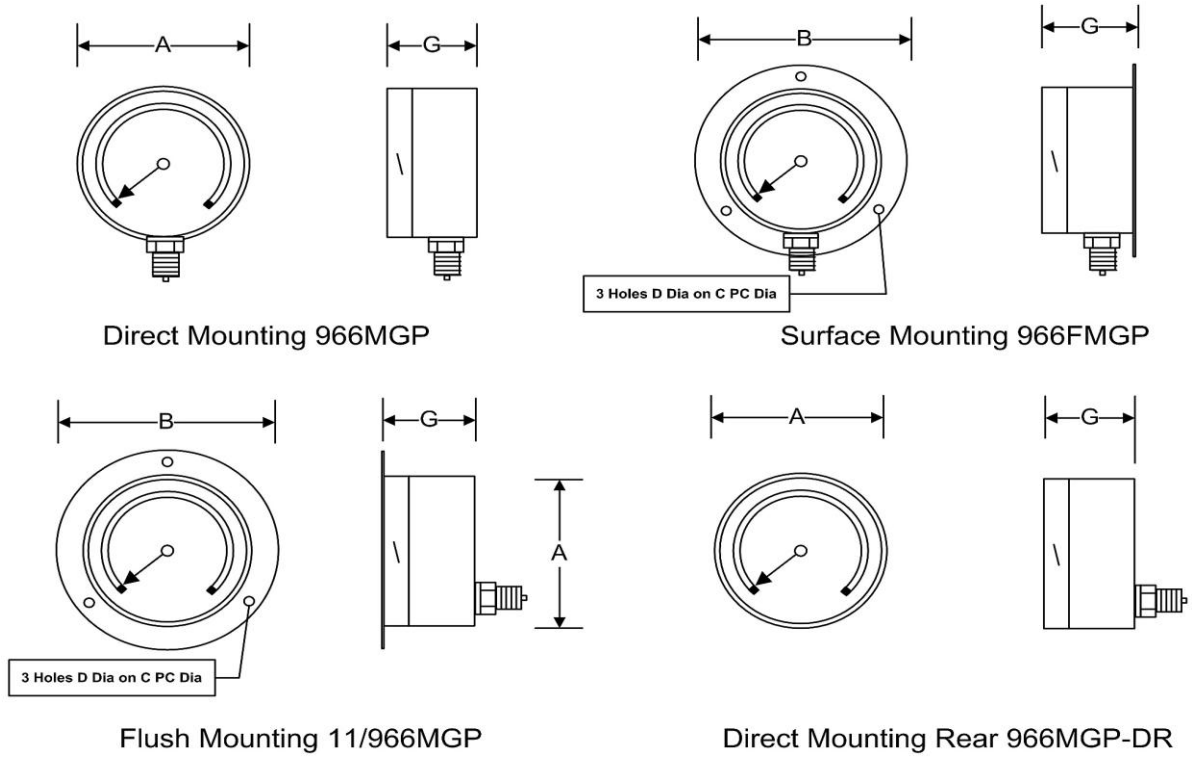

Model No	A	B	C	D	G	Weight
100mm 966 (Dry Case)	105mm	131mm	117mm	6mm	52mm	0.7kg
150mm 966 (Dry Case)	162mm	183mm	168mm	6mm	53mm	1.34kg

Options

- Mounting : Flush mounting clamp fixing available
- Element : 316L Stainless Steel
- Accuracy : 0.5% of FSD as defined in EN837-1
- Window : Acrylic Plastic Window
- Pointer : Micrometer adjustable Model 270

Accessories

For high temperature applications such as steam, see our range of syphons and adaptors. – See separate Datasheet.

We can supply Needle, Ball or 2 Valve manifolds for the Model 966MGP – See separate Datasheet.

The manifolds in addition to allowing the instrument to operate normally allows the following: -

- a). Checking of gauge zero at line pressure.
- b). Complete isolation of the instrument.
- c). De-pressurisation of the instrument or controlled purging.
- d). Damping of pressure pulsations and surges.
- e). Inline calibration, allows in situation calibration