



# Budenberg

Made in Britain

4, Gilchrist Road, Northbank Industrial Park, Irlam, Manchester, UK. M44 5AY.

Tel : +44 (0)161 777 7300

Fax : +44 (0)161 777 7399

Email : sales@budenberg.co.uk

Web : www.budenberg.co.uk

## Model: 180

Model 180 differential pressure gauges are manufactured with a stainless steel diaphragm as the measuring element, the strength of which depends on the differential pressure graduation. The element is isolated from the pressure by two Melinex diaphragms so that only clean oil fills the chamber in which the mechanism operates.

Melinex is a polyester film (polyethylene terephthalate) that is resistant to all petroleum refining industry fluids. Please consult our technical department to check suitability for other chemicals.

This instrument is generally used in applications where the system pressure is very much higher than differential range and can be used for measuring differential pressure in filters, strainers, coolers, pumps, natural gas strainers, orifice plates and venturi tubes.

### Sizes

150mm & 200mm Dial diameter

### Mounting

Surface Mounting – Model 180

Flush Mounting – Model 11/180

### Pressure Connection

3/8" BSP internal as standard

Option : 1/2" BSP & 1/2" NPT external

Material : 316 Stainless Steel

Option : Nickel Aluminium Bronze for Marine duty

### Pressure Element

Stainless Steel Diaphragm

### Accuracy Class

180A & 180B - 1.5% of FSD

180AM & 180BM - 2% of FSD

### Environmental Rating

IP55 as defined in EN 60 529

### Temperature Utilization

Operating: -20 to +90 Degrees C

Storage: -40 up to + 100 Degrees C

### Case

Brass machined casting, Grey finish

Flush mounting version has a black bezel

### Window

3mm Glass, Acrylic or Laminated Glass

### Safety

All gauges are manufactured in accordance with EN837-1

## DIFFERENTIAL PRESSURE GAUGE MICROVAR DIAPHRAGM TYPE



### Scale Ranges

180A Ranges 0 to 0.2 up to 25 Bar MWP 60 Bar

180AM Ranges 0 to 1 up to 25 Bar MWP 60 Bar

180B Ranges 0 to 0.4 up to 25 Bar MWP 140 Bar

180BM Ranges 0 to 1 up to 25 Bar MWP 70 Bar

Option: Central Zero Scales e.g. 1-0-1 Bar

### Applications

Liquids use 180A or 180B

Gases use 180AM or 180BM ( Not Oxygen)

### Dial

White Anodised Aluminium marked in black

Dual scale, bands, sectors are also available

Customisation with Company Name & Logos

### Equalising Valves

Budenberg recommends the use of needle type isolating or equalising valves for use with this instrument, as quick operating valves can cause harmful pressure surges.

Please ask our sales department for details of the full range of Budenberg needle valves

### Snubbers

If pressure surges or fluctuations cannot be eliminated we can offer gauges with an internal snubber which gives a delay of up to 20 seconds.

### Traceability

All individually calibrated and have a unique serial number Certificate of Conformity traceable to National Standards

### Certification Available

BS EN 10204 3.1B certification

Point by Point Test Certificate

**Specification**

**Model : 180**

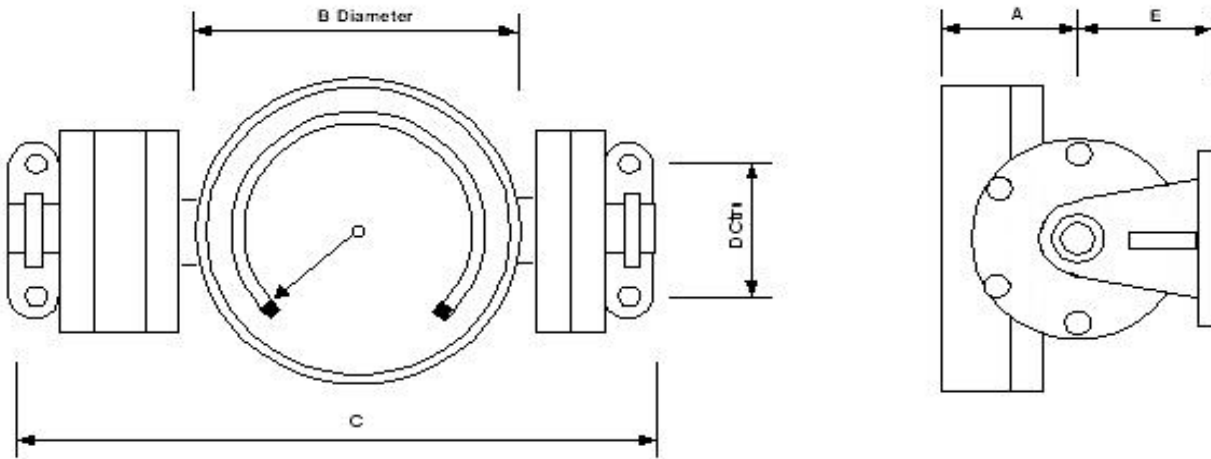

**Microvar Differential Model 180**

\* Shown above with Surface mounting trunnions

Model No 180	A	B	C	D	E	Weight
Microvar	70mm	155mm	290mm	65mm	75mm	9.5 Kg

Microvars for use on :-		Liquids		Gases (Not Oxygen)	
	Model	180A	180B	180AM	180BM
Minimum	Bar	0 to 0.2	0 to 0.4	0 to 1	0 to 1
Differential Range	Psi	0 to 3	0 to 5	0 to 15	0 to 15
Maximum	Bar	0 to 25	0 to 25	0 to 25	0 to 25
Differential Range	Psi	0 to 400	0 to 400	0 to 400	0 to 400
Maximum	Bar	60		60	70
Working Pressure	Psi	850		850	1000

**Accessories**

**Electric Contacts.**

Model 144 Magnetically assisted contacts can be fitted as Single or Double units – See Datasheet on Electric Contacts. On Microvars if Make on Fall contacts are fitted, they are only adjustable over the bottom third of the scale.

**Valves.**

We can supply 3 or 5 Valve manifolds with our differentials – See separate Datasheet on 3 & 5 Valve manifolds. The use of Needle Valves is recommended for equalising or isolating the 'Microvar Differential' since quick operating valves can cause harmful pressure surges. If pressure surges or fluctuations cannot be eliminated we can offer an integral snubber that gives a controlled delay of up to 20 seconds.

The manifolds in addition to allowing the instrument to operate normally allows the following: -

- a). Checking of gauge zero at line pressure.
- b). Complete isolation of the instrument.
- c). De-pressurisation of the instrument or controlled purging.
- d). Damping of pressure pulsations and surges.