

Industrial Range

MODEL

BGH1200

DUAL RANGE TESTER



Hydraulic
Dead-Weight
Testers.

Primary standards
for Pressure
Calibration

▶ Range from
1 - 1200 bar

▶ Standard Accuracy
to 0.015%

▶ Class 'A' Accuracy
to 0.008%

▶ Supplied with
integral pressure
generation



Budenberg

Industrial Range

MODEL

BGH1200

DUAL RANGE TESTER

Hydraulic
Dead-Weight
Testers.

Primary standards
for Pressure
Calibration

Standard Accuracy to 0.015%
Class A with UKAS
Calibration Certificate 0.008%

RANGES:

1200 bar 16000 lb/in²
120000 kPa 1200 kg/cm²

ACCURACY

All certificates issued for Budenberg Dead-weight Testers are fully traceable to national standards via equipment with UKAS calibration certificates. A standard accuracy of 0.015% is achieved from 10% of range using software supplied to compensate for the effects of gravity, temperature and the actual area of piston unit. Standard accuracy without any corrections for actual area is 0.02% from 6 to 1200 bar, 0.025% from 1 to 6 bar. Higher accuracy Class A testers are available (supplied with UKAS Calibration certificates for area and mass) allowing an accuracy of 0.008% to be achieved.

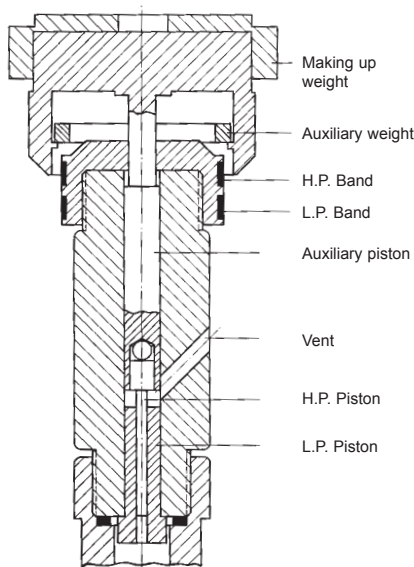

BGH SERIES BASE

The BGH series base can be used with any of the BGH series pistons to give ranges 1 - 120 bar, 2 - 300 bar, 1 - 700 bar, 1 - 1200 bar.

All units are top loading for ease of use and weight sets are fully interchangeable. This means that weight sets in alternative pressures are readily available and customers with more than one BGH series tester can interchange weight sets between tester of the same range.

The base features a dual area screwpress which allows low pressure priming and high pressure control.

The BGH1200PCU is a dual area piston / cylinder unit with 1/8in² and 1/160in² areas. Changing between ranges is fully automated meaning that users have an extremely flexible instrument covering the range with one piston / cylinder assembly and one weight set. The low pressure piston / high pressure cylinder is tungsten carbide, other parts are fully hardened and stabilised tool steel.

Please note: Due to Budenberg's policy of continuous improvements, specifications may be subject to change without notice.

WEIGHTS SUPPLIED

bar or kg/cm ²	kPa	lb/in ²
Low range 1-60	Low range 100-6000	Low range 10-800
High range 20-1200	High range 2000-120000	High range 200-16000
Piston 1 or 20 1 wt 9 or 180 4 wts 10 or 200 1 wt 5 or 100 2 wts 2 or 40 1 wt 1 or 20 1 wt 0.5 or 10	Piston 100 or 2000 1 wt 900 or 18000 4 wts 1000 or 20000 1wt 500 or 10000 2 wts 200 or 4000 1wt 100 or 2000 1wt 50 or 1000	Piston 10 or 200 1 wt 90 or 1800 6 wts 100 or 2000 1 wt 50 or 1000 2 wts 20 or 400 1 wt 10 or 200 1 wt 5 or 100
Optional fine increment weights 2 wts 0.2 or 4 1 wt 0.1 or 2 1 wt 0.05 or 1 2 wts 0.02 or 0.4 1 wt 0.01 or 0.2	2 wts 20 or 400 1wt 10 or 200 1wt 5 or 100 2 wts 2 or 40 1wt 1 or 20	2 wts 2 or 40 1 wt 1 or 20 1 wt 0.5 or 10 2 wts 0.2 or 4 1 wt 0.1 or 2

ACCESSORIES

There are many accessories which can be supplied for use with the Dead-weight testers. These include liquid / liquid seals, two gauge stands and many others. Budenberg have extensive experience in the use of Dead-weight testers and can supply accessories for many applications. A separate data sheet of accessories is available.

PACKING DETAILS

1 carton containing base, tool roll and piston unit:
59 x 49 x 38cm. 0.110m³, Nett 20kg, Gross 22kg.
2 x cartons containing weights:
32 x 32 x 31cm. 0.04m³, Nett 25kg, Gross 30kg. ea

SPARES, REPAIR AND RE-CERTIFICATION

Comprehensive service and calibration capability of both Budenberg and non Budenberg test equipment:
Dead-weight Testers (working service or full overhaul).
Gauges (all types, all manufacturers).
Portable calibrators (Budenberg & non- Budenberg).
Comparators.
All accuracy ranges can be supplied with UKAS Calibration Certificates, or, Certification traceable to national standards.
Rapid turn-around times and hire items available as a temporary replacement for strategically important plant.

For further information on Accessories, and other product information contact Budenberg and ask for a Data sheet.



Budenberg Gauge Co. Ltd.

Unit B2, Stuart Road,
Altrincham Business Park,
Altrincham WA14 5GJ,
United Kingdom.

Tel: +44 (0)161 777 7300
Email: sales@budenberg.co.uk
Website: www.budenberg.co.uk

Budenberg Gauge Pvt. Ltd.

299-300, IInd Main Road,
Nehru Nagar,
Old Mahabalipuram Road (OMR),
Chennai - 600 096,
Tamil Nadu , India

Tel : +91 44 24541074
Tel/Fax: +91 44 24541075
Email: sales@budenberg-gauge.in

Budenberg Gauge Asia
Pacific Ltd

Unit 7A G/F Cheung Fat Ind
Bldg 64-76 Larch St Tai Kok
Tsui Kln
Hong Kong

Tel : +852 3709 0020
Email: sales@budenberg-gauge.asia

Budenberg Middle East LLC

PO Box 18980
Dubai
United Arab Emirates

Tel: +971 4 2511670
Email: sales@budenberg-me.org